

## ▼HDMI2.0 Solution:

Surge level: Contact 8KV Air 15KV

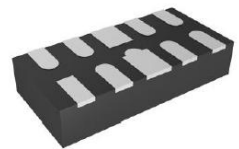
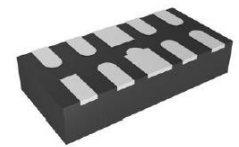
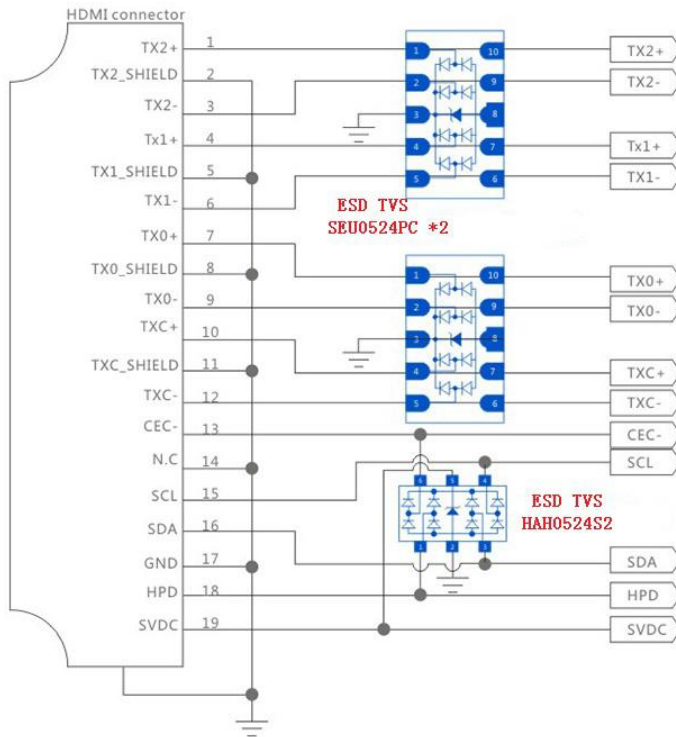

## Specification.....

Part Number	VRWM	VBR	Co Typical value	Vc @1A	Ppp 8/20us	Package	ESD Air / Contact
<b>ESD TVS</b>	<b>V</b>	<b>V</b>	<b>pF</b>	<b>V<sub>max</sub></b>	<b>W</b>		
<b>SEU0524PC</b>	<b>5</b>	<b>6</b>	<b>1</b>	<b>9.0</b>	<b>100</b>	<b>DFN2510-10</b>	<b>±8kV / ±15kV</b>

Part Number	VRWM	VBR	Co Typical value	Vc @1A	Ppp 8/20us	Package	ESD Air / Contact
<b>ESD TVS</b>	<b>V</b>	<b>V</b>	<b>pF</b>	<b>V<sub>max</sub></b>	<b>W</b>		
<b>HAH0524S2</b>	<b>5</b>	<b>6</b>	<b>1</b>	<b>9.0</b>	<b>80</b>	<b>SOT23-6L</b>	<b>±10kV / ±15kV</b>

We focus on development, production,distribution of GDT,TSS.MOV,TVS,ESD,PTC component.We have laboratories of EMC,aiming to provide total turnkey service of surge/ESD test and circuit PCB improvement.

[sales@huaandz.com](mailto:sales@huaandz.com)